

MECHANICAL CASE OUTLINE
PACKAGE DIMENSIONS

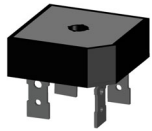

GBPC4 28.75x28.75x11.10, MODEL 1
CASE 160AD
ISSUE C

DATE 15 NOV 2023

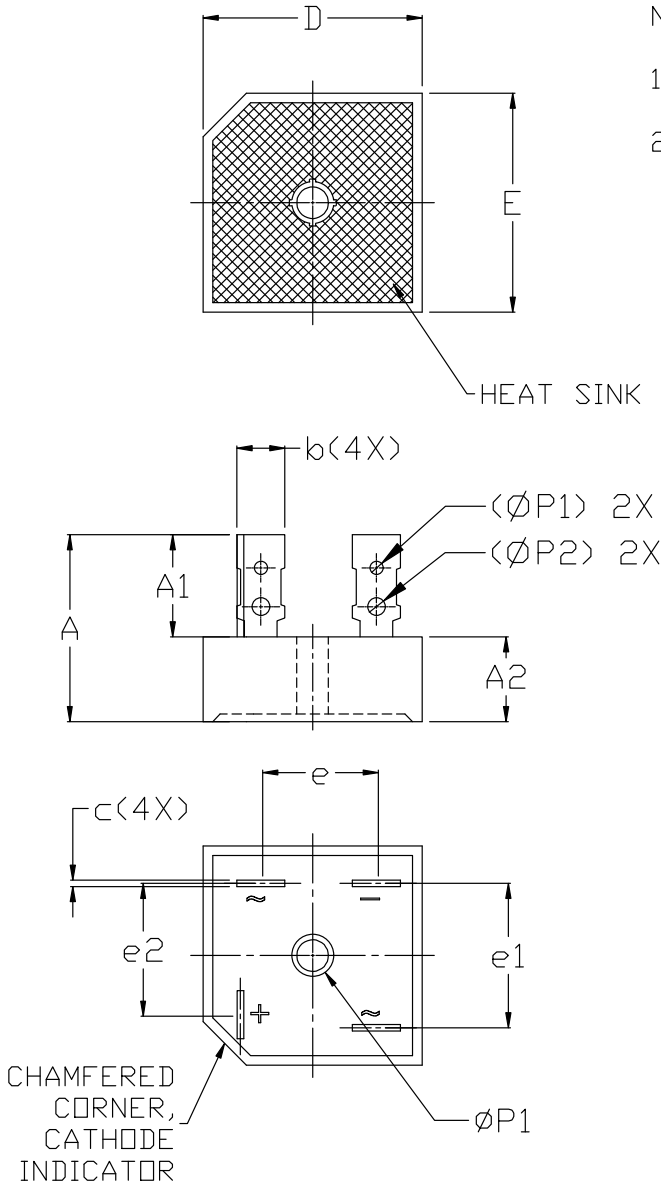

NOTES:

1. DIMENSIONING AND TOLERANCING CONFORM TO ASME Y14.5-2018.
2. ALL DIMENSION ARE IN MILLIMETERS.

DIM	MILLIMETERS		
	MIN.	NOM.	MAX.
A	21.500	23.000	24.500
A1	13.270 REF		
A2	10.970	11.100	11.230
ØP	5.080	5.335	5.590
ØP1	1.780 REF		
ØP2	2.360 REF		
D	28.500	28.750	29.000
E	28.500	28.750	29.000
b	6.350 TYP		
c	0.760	0.810	0.860
e	13.300	14.300	15.300
e1	17.100	18.100	19.100
e2	15.500	16.550	17.600

DOCUMENT NUMBER:	98AON13489G	Electronic versions are uncontrolled except when accessed directly from the Document Repository. Printed versions are uncontrolled except when stamped "CONTROLLED COPY" in red.
DESCRIPTION:	GBPC4 28.75x28.75x11.10, MODEL 1	PAGE 1 OF 2

onsemi and **ONSEMI** are trademarks of Semiconductor Components Industries, LLC dba **onsemi** or its subsidiaries in the United States and/or other countries. **onsemi** reserves the right to make changes without further notice to any products herein. **onsemi** makes no warranty, representation or guarantee regarding the suitability of its products for any particular purpose, nor does **onsemi** assume any liability arising out of the application or use of any product or circuit, and specifically disclaims any and all liability, including without limitation special, consequential or incidental damages. **onsemi** does not convey any license under its patent rights nor the rights of others.

MECHANICAL CASE OUTLINE
PACKAGE DIMENSIONS

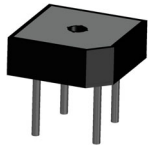

GBPC4 28.75x28.75x11.10, MODEL 2
CASE 160AD
ISSUE C

DATE 15 NOV 2023

NOTES:

1. DIMENSIONING AND TOLERANCING CONFORM TO ASME Y14.5-2018.
2. ALL DIMENSION ARE IN MILLIMETERS.

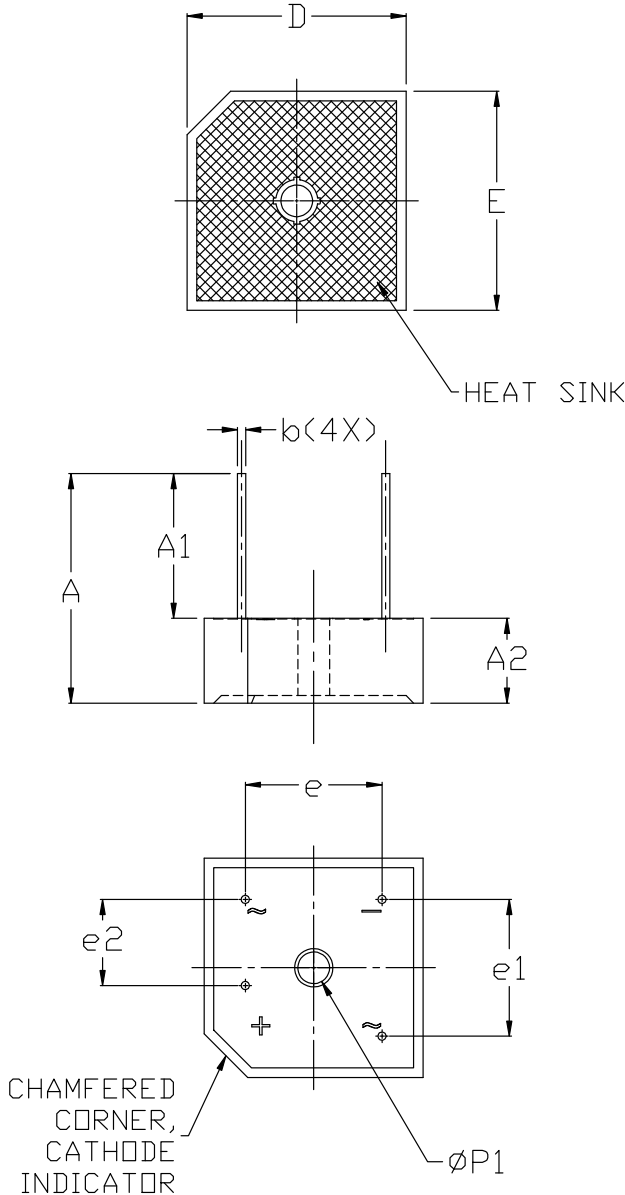

DIM	MILLIMETERS		
	MIN.	NOM.	MAX.
A	30.500	---	---
A1	19.270 REF		
A2	10.970	11.100	11.230
ϕP	5.080	5.335	5.590
D	28.500	28.750	29.000
E	28.500	28.750	29.000
b	0.970	1.020	1.070
e	17.100	18.100	19.100
e1	17.100	18.100	19.100
e2	10.400	11.400	12.400

DOCUMENT NUMBER:	98AON13489G	Electronic versions are uncontrolled except when accessed directly from the Document Repository. Printed versions are uncontrolled except when stamped "CONTROLLED COPY" in red.
DESCRIPTION:	GBPC4 28.75x28.75x11.10, MODEL 2	PAGE 2 OF 2

onsemi and ONSEMI are trademarks of Semiconductor Components Industries, LLC dba onsemi or its subsidiaries in the United States and/or other countries. onsemi reserves the right to make changes without further notice to any products herein. onsemi makes no warranty, representation or guarantee regarding the suitability of its products for any particular purpose, nor does onsemi assume any liability arising out of the application or use of any product or circuit, and specifically disclaims any and all liability, including without limitation special, consequential or incidental damages. onsemi does not convey any license under its patent rights nor the rights of others.